

ENSUREAL and the Pedersen Process Concept for a more sustainable alumina industry

Contact:

KON Chemical Solutions e.U.

www.kon-chem.com

Office@kon-chem.com

+43 699 11 77 99 33



Grant Agreement N° 767533

Key Findings:

- Pedersen can digest different feed materials
- Bauxite Residuals and a reunion of Bayer and Pedersen is now the most promising concept at mid term
- A stand alone Pedersen plant might be interesting for special bauxites or Al & iron containing feed materials.
- Alumina refineries generate a new value chain with by producing pig iron from the same raw martial and eliminate a waste stream
- Cheap and sustainable electricity will be a driving force for site decision



Situation Today

- **95% of annually produced Alumina uses the Bayer route ¹⁾**
- **132 Mio. ton Alumina in total 2019 ¹⁾**
- **to produce 63,7 Mio. ton primary Aluminum ¹⁾**
- **160 Mio. ton Bauxite Residue (BR) in total 2019 ¹⁾**
- **Only about 3% of BR were used productively 2016 ²⁾**



Data Source:

1) <https://www.world-aluminium.org/statistics/>

2) Evans, K. (2016). "The History, Challenges, and New Developments in the Management and Use of Bauxite Residue." *Journal of Sustainable Metallurgy* 2(4): 316-331



Original Pedersen Process

FLOW SHEET OF THE PEDERSEN PROCESS

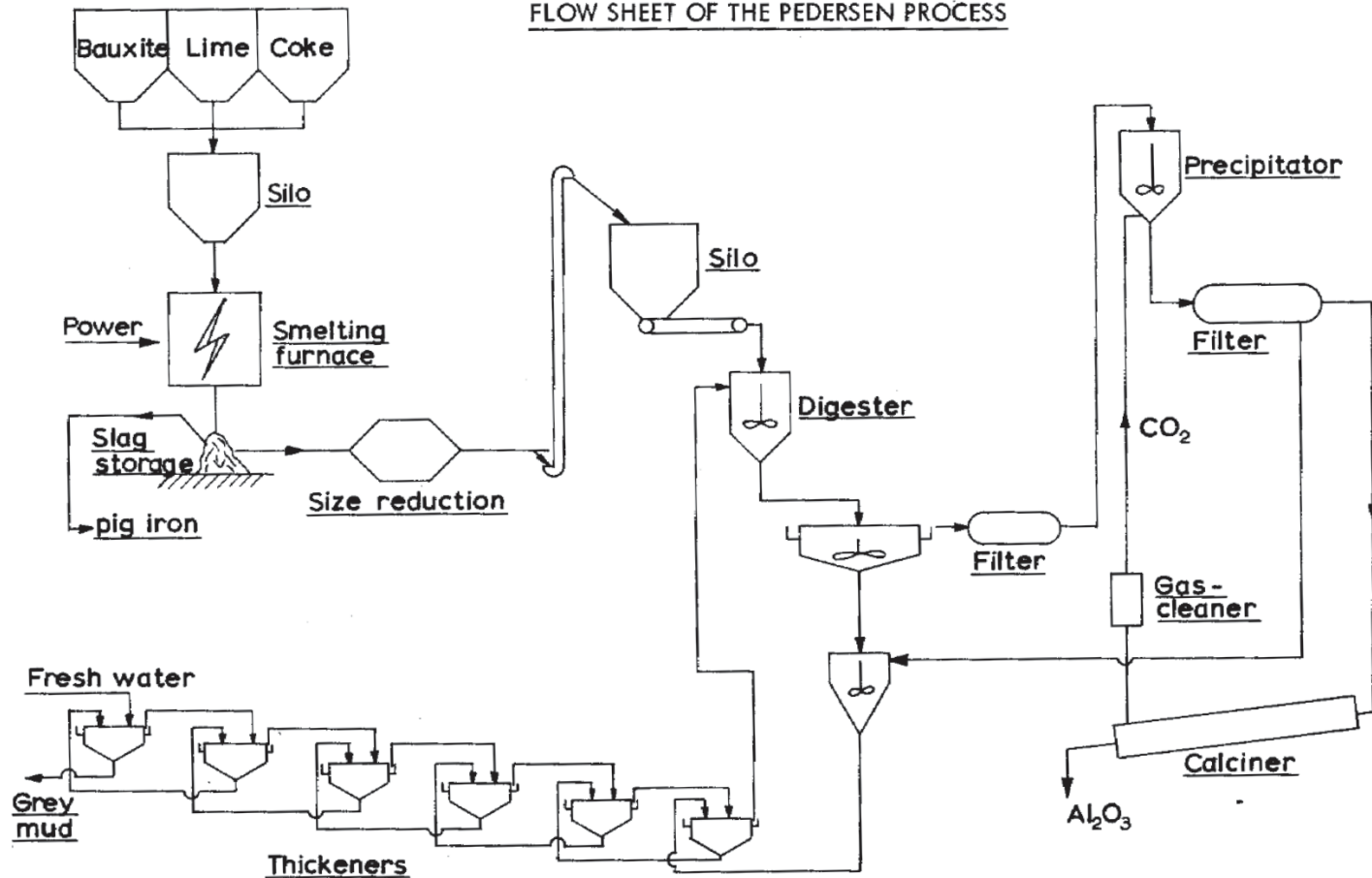

- Smelting bauxite or another Al source
- Generating a Ca/Al slag
- Leaching with NaCO₃ = baking powder
- Precipitation with CO₂
- Roasting for Al₂O₃ production
- CaCO₃ gray mud as byproduct

Data Source:

Miller, J. and A. Irgens (1974). Alumina Production by the Pedersen Process — History and Future. Essential Readings in Light Metals: Volume 1 Alumina and Bauxite. D. Donaldson and B. E. Raahauge. Cham, Springer International Publishing: 977-982.



Industrial Process Concept

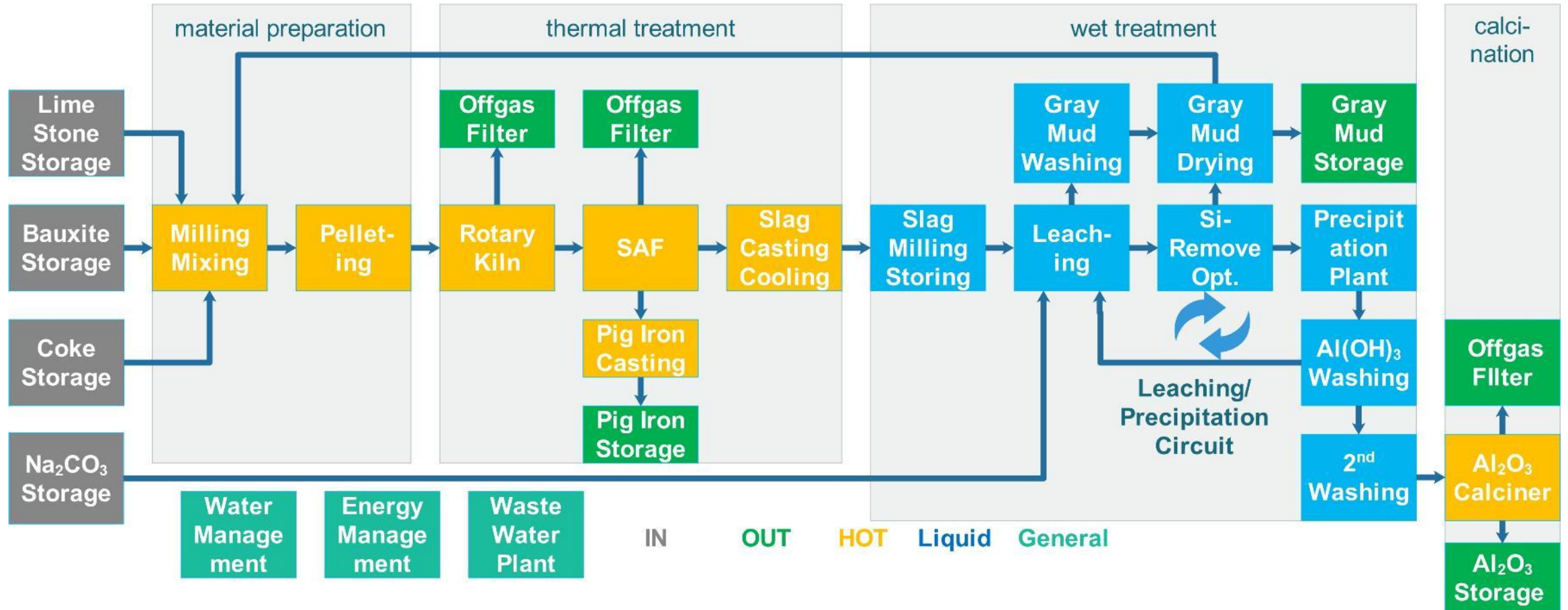

Sankey Diagram Current Status (500 kt Alumina per annum)

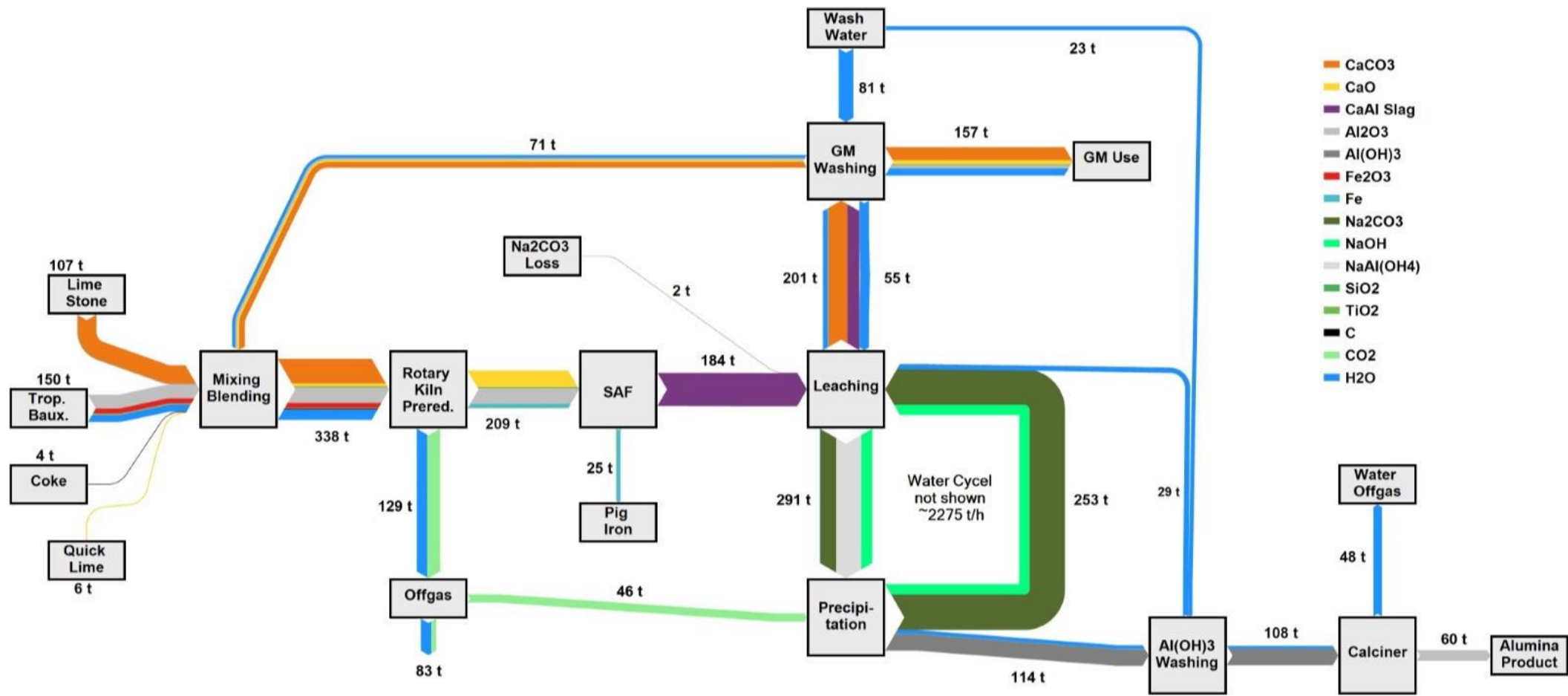

- CaCO₃
- CaO
- CaAl Slag
- Al₂O₃
- Al(OH)₃
- Fe₂O₃
- Fe
- Na₂CO₃
- NaOH
- NaAl(OH)₄
- SiO₂
- TiO₂
- C
- CO₂
- H₂O



Process Flow Development

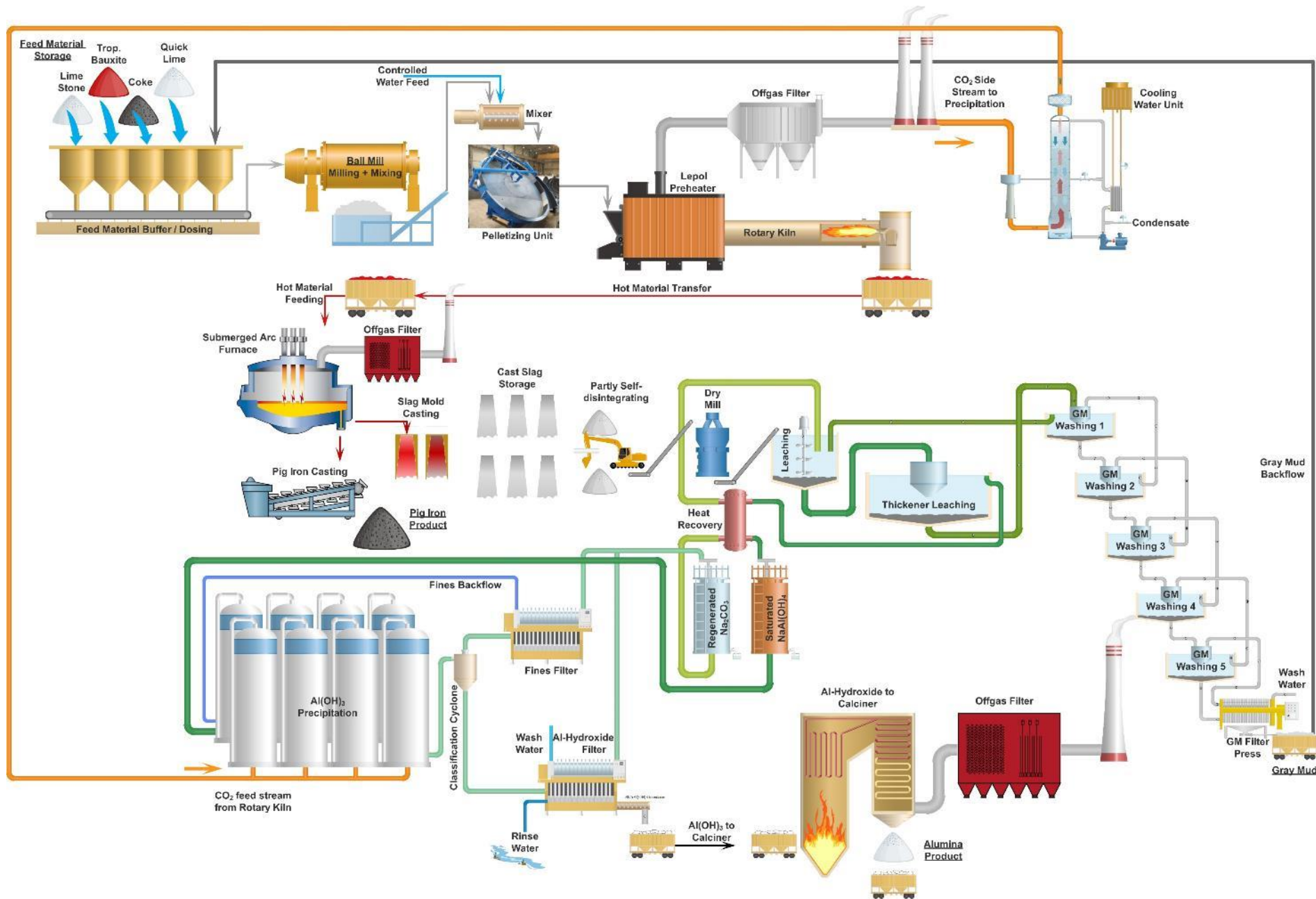

Layout concept- material flow

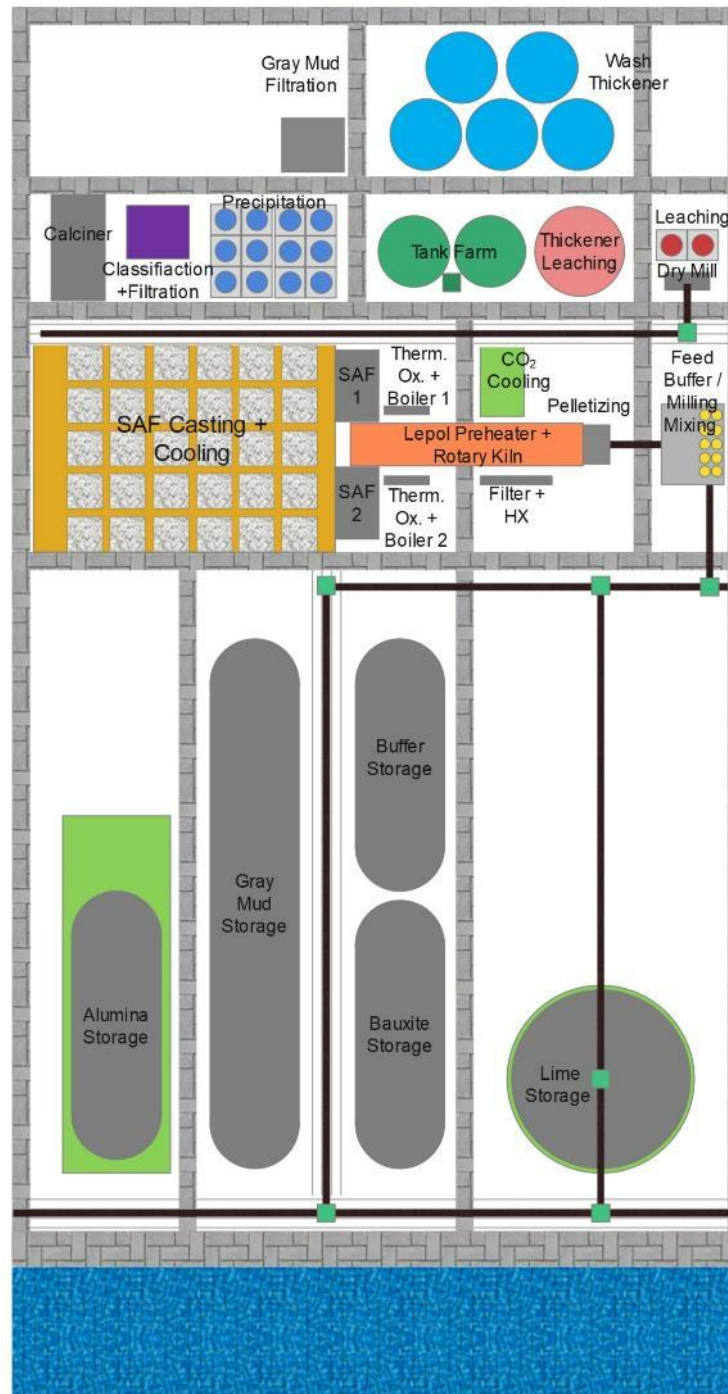

- Green field project
- Free design possible
- Staff infrastructure not considered yet
- Port infrastructure assumed as given
- Approx. 50% space for storage
- Utilities like water, cooling water and electricity are supplied from outside

FAM GmbH- Storage Supplier

Main used Equipment:

Ship Unloader

Conveying System

Stockyard Technology:

Circular Stacker-Reclaimer

Stacker-Reclaimer

Capacity/year:

- ~ 900 kt Limestone
- ~ 1.250 kt Bauxit
- ~ 33 kt Kohle
- ~ 17 kt Na₂CO₃
- ~ 1.300 kt Gray Mud



FAM GmbH
Sudenburger Wuhne 47
39112 Magdeburg, Germany

Tel: +49 391 6380 0
E-Mail: sales@fam.de
Web: www.fam.de



CEMTEC Cement and Mining Terchnology GmbH- Supplier Milling, Pelleting, Silos

Main used equipment:

- Ball mill- size 4,8 x 15 meter
- Silos – about 16 meter high
- Peletizing disc- design capacity 198t/h
- High Intensive Mixer- design capacity 420t/h

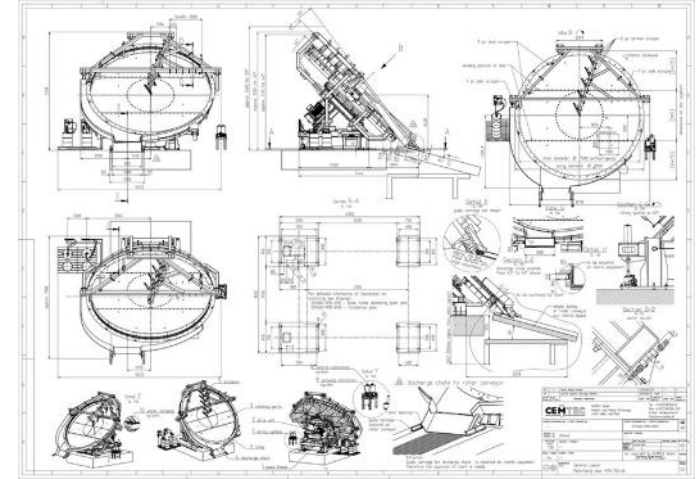
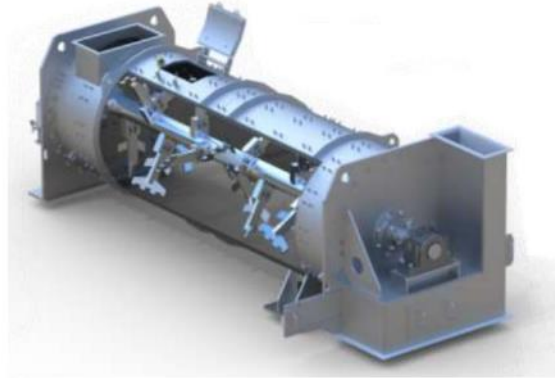

CEMTEC

CEMTEC Cement and Mining Technology GmbH
Ennschafenstrasse 40
4470 Enns Austria

Tel: +43 7223/ 83620-0
E-Mail: info@cemtec.at
Web: www.cemtec.at

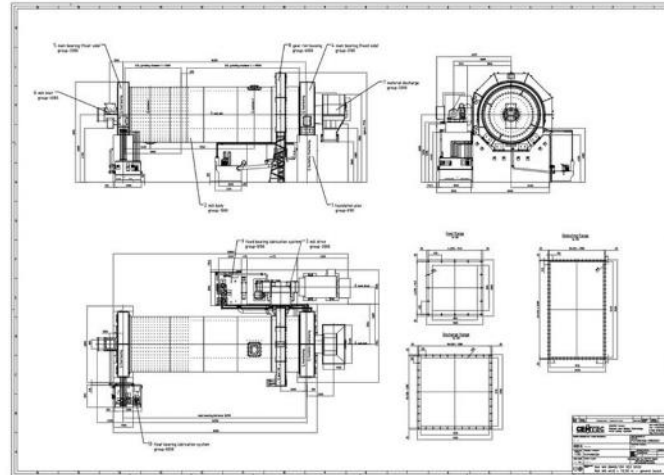

Thyssenkrupp Industrial Solutions AG- Supplier

Lepol preheater- rotary kiln

Main used equipment:

2x travelling grate preheater LEPOL type 3929
for each 3000 t/d capacity
2x rotary kiln 4.6 m diameter x 70 m length
in combination



Thyssenkrupp Industrial Solutions AG
Graf- Galen- Straße 17
59267 Beckum, Germany

Tel: +49 2525 99-0
E-Mail: info.industrial-solutions@thyssenkrupp.com
Web: www.thyssenkrupp-industrial-solutions.com



Metso:Outotec- Supplier

Main equipment:

- 1 OTOVENT™ Quench incl. brick lining and nozzles
- 3 OTOVENT Pumps with motors
- 3 Strainers
- 1 Overflow Pot
- 1 Emergency Water Tank
- 1 Packed Gas Cooling Tower PGCT incl. internals
- 3 PGCT Pumps with motors
- 3 Plate Heat Exchangers
- Duct between OTOVENT™ Quench and PGCT

Metso:Outotec

Outotec GmbH & Co. KG
In der Schwarzwiesen 13
61440 Oberursel, Germany

Tel: +49 6171 9693 331
E-Mail: jochen.gruenig@mogroup.com
Web: www.mogroup.com



BlueMetals GmbH- Supplier- SAF/ Offgas Filter

Main used equipment:

Submerged Arc Furnances

Electric Smelters: Concepts,

Dimensioning, Design,

Engineering

25 years experience



Bluemetals GmbH

Klotzdelle 15d

45472 Mülheim an der Ruhr, Germany

Tel: +49 208 694 7563

E-Mail: info@bluemetals.com

Web: www.bluemetals.de

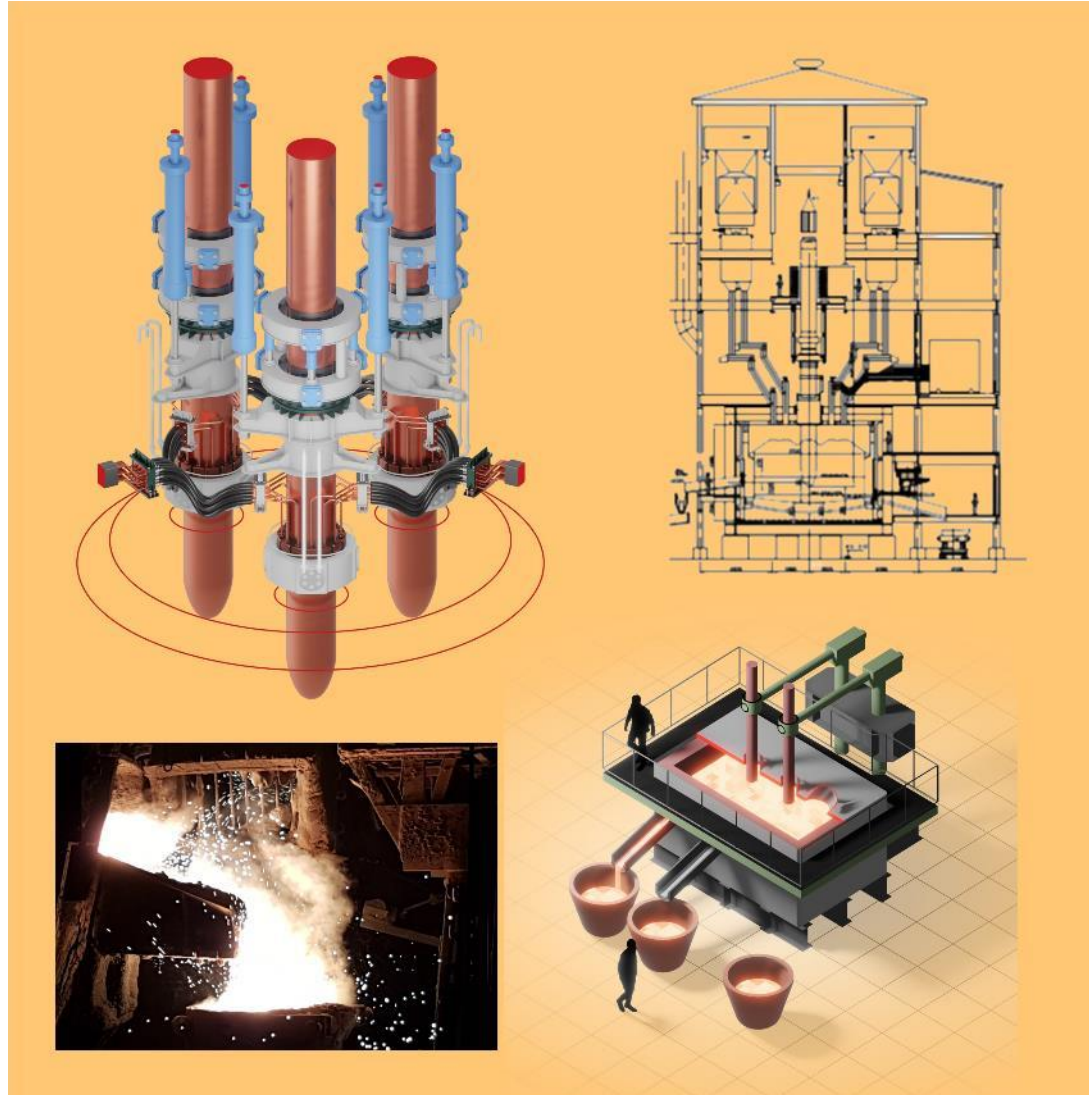

DELKOR by TAKRAF GmbH- Thickener, Leaching and Filterpress Supplier

Main used equipment:

Overhead beam Filter Press

5 Wash thickener – 40m diameter

1 Leach thickener – 50m diameter

DELKOR

TAKRAF

TAKRAF GmbH

Torgauer Strasse 336

04347 Leipzig – Germany

Tel: +49 341 2423 500

E-Mail: info@takraf.com

Web: www.takraf.com



Alfa Laval Mid Europe GmbH-Supplier Heat Exchanger

Main used equipment:
Heat Exchanger TL35- BFM



Alfa Laval Mid Europe GmbH
IZ-NÖ-Süd, Strasse 2/M7/1
2355 Wiener Neudorf – Austria

Tel: +43 2236 68 20
E-Mail: info.mideurope@alfalaval.com
Web: www.alfalaval.at

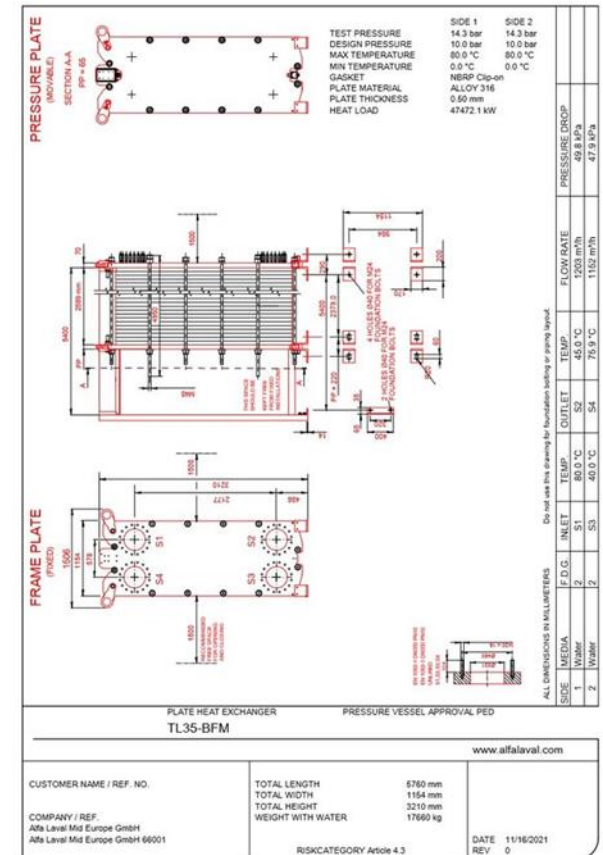

Eurotankworks- Supplier Tank Farm

Main used equipment

2 Storage tanks- volume each tank 20.000 m³



EUROTANKWORKS OÜ
Vesivärava 50-201
10152, Tallinn, Estonia

Tel: +372 698 74 66
E-Mail: info@etw.ee
Web: www.etw.ee



Height 17,8m
Diameter 40 m

AKW Apparate + Verfahren GmbH – Supplier Hydrocyclone

Main equipment used:

AKA-SPIDER Distributors equipped with
AKA-VORTEX Hydrocyclones, TWIN type
Capacity 500m³/h per each Distributor



Equipment + Process Design

AKW Apparate + Verfahren GmbH

Dienhof 26

92242 Hirschau, Germany

Tel: +49 9622 7039 0

E-Mail: akwauv@akwauv.com

Web: www.akwauv.com

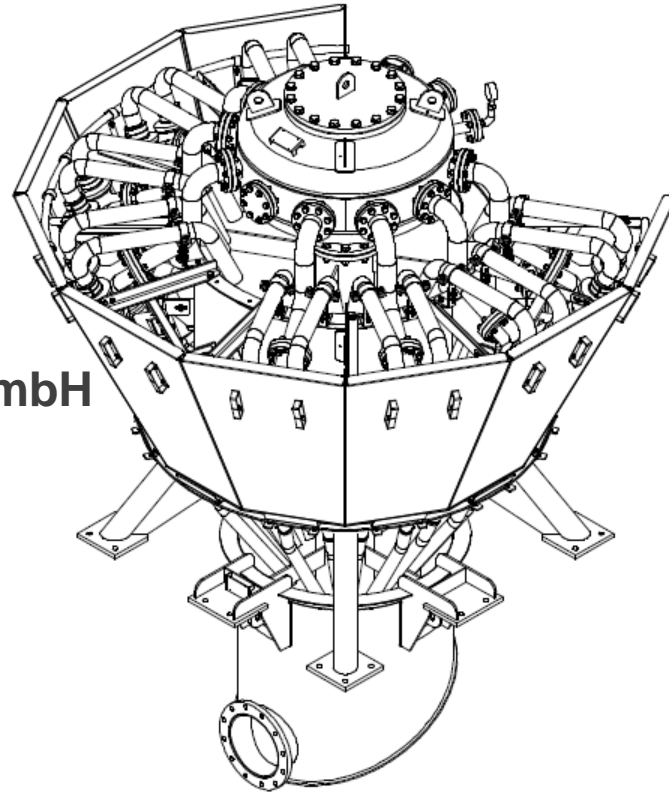

BOKELA GmbH- Supplier Filter

Main used Equipment:

- BoVacDisc L176 for Al-hydrate seed filtration, disc diameter about 6 m
- BoVacPan M43 for Al-hydrate product washing and dewatering, pan diameter about 8 m

BOVAC DISC FILTER

Main Components

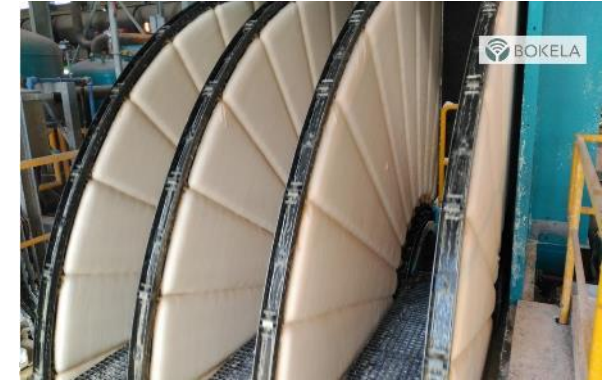
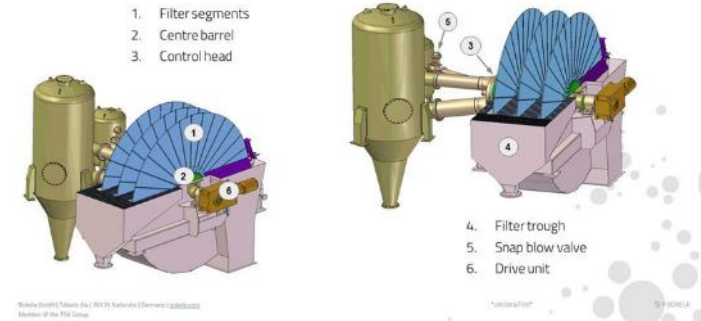

BOKELA GmbH
Tullastraße 64
76131 Karlsruhe, Germany

Tel: +49 721 96456-0
E-Mail: info@bokela.com
Web: www.bokela.com

MAIN COMPONENTS OF THE BOVAC PAN FILTER

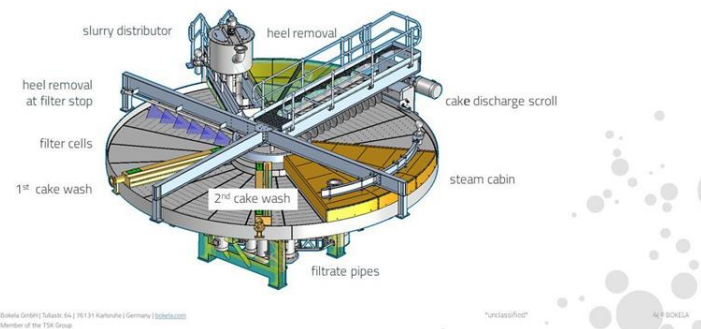

Metso:Outotec- Supplier Calciner

Main equipment:

- 1 Fluidized bed hydrate dryer
- 1 Electrostatic Precipitator
- 1 Circulating fluidized bed reactor
- 1 Mixing pot
- 3 Lift ducts
- 1 Fluidized bed cooler
- Seal pots
- 3 Venturi suspension preheaters
- 2 Preheating cyclones
- 1 Lifting cyclone
- 3 Cooling cyclones
- Blowers for process gas



Metso:Outotec

Outotec GmbH & Co. KG
In der Schwarzwiesen 13
61440 Oberursel, Germany

Tel: +49 6171 9693 331
E-Mail: jochen.gruenig@mogroup.com
Web: www.mogroup.com



ANDRITZ- Supplier pumps

Main used equipment

ACP350-480.6S – 2400m³/h Head 60m

ACP100-500.6W – Head 120m

ACP400-700.3W – 2970 m³/h Head 40m

ACP450-410.4S – 2350m³/h



ANDRITZ AG
Stattegger Straße 18
8045 Graz, Austria

Tel: +43 316 6902 1456
E-Mail: pumps@andritz.com
Web: www.andritz.com/pumps

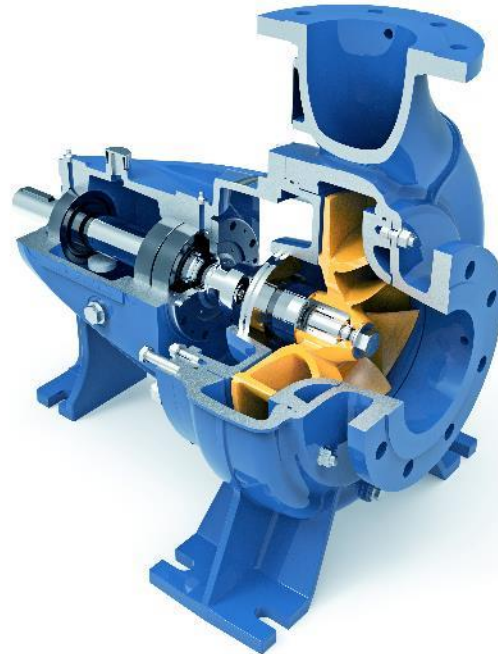

Dissemination activities



World exhibition in Dubai



KonChem meets Dr. Schramböck - economy minister of Austria

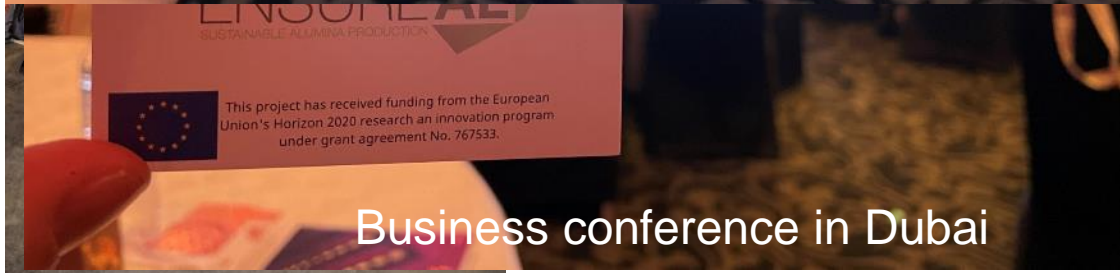

Business conference in Dubai



Samples

Videos at youtube- examples



<https://youtu.be/j6s59TXrcJY>

Austria connect in Dubai

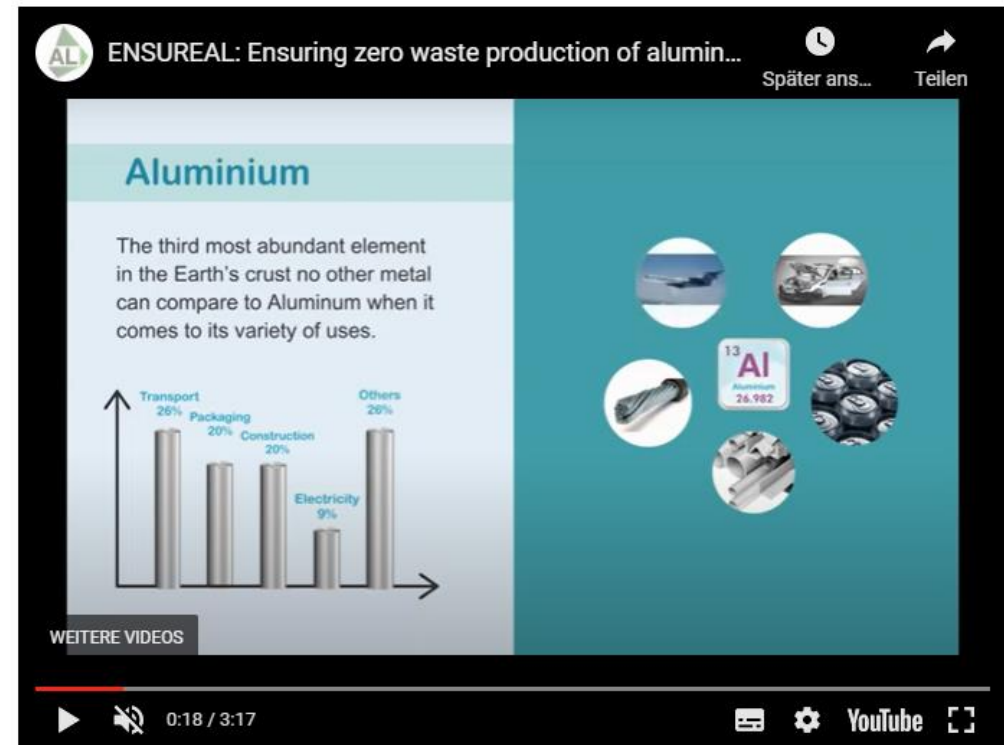

<https://youtu.be/szauU4b7KDE>

Concept Video- Ensuring zero waste production of alumina in europe



Grant Agreement N° 767533



Outlook

- Ongoing discussion with Saudi Arabia about the process and a possible next steps
- Contact with different stakeholder about the project and the current situation
- Addition targeted dissemination activities based on generates results will generate additional impact.



The floor is open for questions

more information also @

www.ensureal.com

and

Dr. David Konlechner

david.konlechner@kon-chem.com

+43 699 11 77 99 33



Grant Agreement N° 767533